

WATER TRI-EXTENSION SCUPPER LIPS

WATER TRI-EXTENSION
RUBBER SCUPPER LIP

PART NO: 15-1094R

NAVY MOLD: 1376-A

BIW CAT NO: 54165-005

BIW DRAWING # 8100-5220-0003 REV M

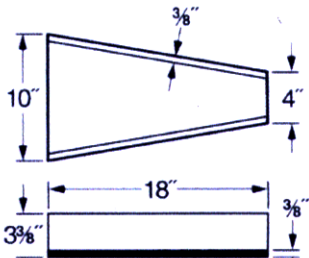

SCUPPER and HARDWARE KIT

PN: 15-1094RCK



WATER TRI-EXTENSION RUBBER
SCUPPER LIP NAVY MOLD 1376-A
MODIFIED TO BIW CAT NO: 54665-083

DIM A - 4" DIM B - 8-1/4"

BIW DRAWING # 8100-5220-0003

PN: 15-1094R-MOD

WATER TRI-EXTENSION
RUBBER SCUPPER KIT

INCLUDES RUBBER SCUPPER TRI-EXTENSION
316SS BRACKET and HARDWARE

BIW CAT NO: 54665-083

BIW DRAWING # 8100-5220-0003 REV L

PART NO: 15-1094RCK-MOD



RUBBER TRI SCUPPER
PART NO: 15-4610R
15-3/4" X 11" X 18"
BIW CAT NO: 54165-013
BIW DRAWING # 8100-5220-0003 REV M

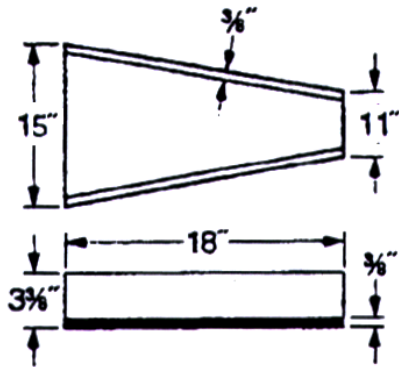

TRI SCUPPER
COMPLETE KIT
PART NO: 15-4610RCK
INCLUDES TRI-SCUPPER
316SS BRACKET and HARDWARE

BIW CAT NO: 54665-130
BIW DRAWING # 8100-5220-0003 REV L



SAN DIEGO SEAL, INC.

7635 RONSON ROAD • SAN DIEGO, CALIFORNIA 92111

TEL: 858-278-3270 • FAX: 858-278-2950

E-MAIL: sales@sandiegoseal.com • VISIT US AT: www.sandiegoseal.com